

FROMM

OPERATION MANUAL / SPARE PARTS LIST

MANUAL SEALLESS STEEL STRAPPING TOOL

MODEL A332

13.2250.01

	INDEX	PAGE
1	SAFETY INSTRUCTIONS	2
2	WARRANTY CONDITIONS AND LIABILITY	3
3	APPROPRIATE USE	3
4	TECNICAL DATA	3
5	CHART OF TYPES A332	4
6	OPERATION	4
7	SPARE PARTS LIST 13.2250.01	8
8	SEAL CONTROL	10
9	SEAL ADJUSTMENT	11
10	CLEANING	11
11	ACCESSORIES	12

Distributed By:

Allstrap

1719 Kenny Rd
Columbus, OH, 43212

1 SAFETY INSTRUCTIONS

Read these instructions carefully. Failure to follow these instructions can result in severe personal injury.

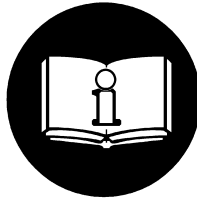

Eye injury hazard

Failure to wear safety glasses with side shields can result in severe eye injury or blindness. Always wear safety glasses with side shields which conform to ANSI Standard Z87.1.



Operation

Tool must not be used by persons not properly trained in their use. Before tensioning strap, read and understand the tool operating instructions. Failure to follow the operating instructions or improper load positioning could result in strap breakage.

Become familiar with your tool and keep fingers away from areas that can pinch or cut.

Joints

You are fully responsible to review the joints made by your tool. Become familiar with the seal control and seal adjustment described in this operation manual. Misformed joints may not secure the load and could cause serious injury. Never handle or ship any load with improperly formed joints.

Dispensing strap

Only dispense strap from a dispenser specifically designed for strap.

Tuck strap end back into dispenser when not in use.

Protective gloves

When handling strap, always wear protective gloves.



Strap warnings

Never use strap as a means of pulling or lifting loads. Failure to follow these warnings can result in severe personal injury.

Strap breakage hazard

Improper operation of the tool, excessive tensioning, using strap not recommended for this tool or sharp corners on the load can result in a sudden loss of strap tension or in strap breakage during tensioning, which could result in the following:

- A sudden loss of balance causing you to fall.
- Both tool and strap flying violently towards your face.

Note as follows:

- If the load corners are sharp, use edge protectors.
- Place the strap correctly around a properly positioned load.
- Positioning yourself in-line with the strap, during tensioning and sealing, can result in severe personal injury from flying strap or tool. When tensioning or sealing, position yourself to one side of the strap and keep all bystanders away.
- Use the correct strap quality, strap width, strap gauge and strap tensile strength recommended in this manual for your tool. Using strap not recommended for this tool can result in strap breakage during tensioning.

Cutting tensioned strap

When cutting strapping, use the proper strapping cutter and keep other personnel and yourself at a safe distance from the strap. Always stand to side of the strap, away from the direction the loosened strap end will fly. Use only cutters designed for strap and never hammers, pliers, hacksaws, axes, etc.

Fall hazard

Keep your working area tidy. Untidiness of your working area may cause a risk of injury. Maintaining improper footing and/or balance when operating the tool can cause you to fall. Before tensioning and especially in elevated areas, always establish good balance. Both feet should be securely placed on a flat, solid surface, especially when working in elevated areas. Do not use the tool when you are in an awkward position.

Pay attention to the rules and regulations for preventions of accident which are valid for the work place.

Tool hazards

A well maintained tool is a safe tool!

Check tool regularly for broken or worn parts. Do not operate a tool with broken or worn parts.

Never modify any tool. Modification can result in severe bodily injury.

Distributed By:

Allstrap

1719 Kenny Rd

Columbus, OH, 43212

2 WARRANTY CONDITIONS AND LIABILITY

FROMM Holding AG warrants all its strapping tools and machine heads during a period of 90 days from the date of sale. The warranty includes all deficiencies clearly resulting from poor manufacturing or faulty materials. Damage claims as a result of production shutdowns and claims for damage to persons and to property resulting from warranty deficiencies cannot be asserted by the customer.

The warranty excludes:

- wearing parts
- deficiencies resulting from improper installing, incorrect handling and maintaining the tool
- deficiencies resulting from using the tool without or with defective security- and safety devices
- disregard of directions in the operation manual
- arbitrary modifications of the tool
- deficient control of wearing parts
- deficient repair works of the tool
- Use of consumable products not recommended by FROMM Holding AG

We reserve the right to modify the product at any time in order to improve its quality.

3 APPROPRIATE USE

The tool model A332 has been designed to strap packages with steel strapping exclusively.

The warranty / liability excludes:

- non appropriate use of the tool,
- disregard of directions in the operation manual,
- disregard of control- and maintenance instructions.

4 TECHNICAL DATA

Dimensions without suspension bracket

	Tool	Package
Length:	385 mm / 15.2"	405 mm / 15.9"
Width:	141 mm / 5.6"	360 mm / 14.2"
Height:	310 mm / 12.2"	165 mm / 6.5"
Weight:	3.3 kg / 7.3lbs	0.95 kg / 2.1lbs

Joint strength

Approx. 80% of the strap's tensile strength.

Steel strapping

Width:	9.5 - 13 mm / 3/8"-1/2" (see chart of types)
Thickness:	0.38 - 0.50 mm / 0.015"- 0.020"
Quality:	Fundamentally the A332 allows the use of all current steel straps with tensile strengths ranging from 700 to 850 N/mm ² / 100 000 - 123 000 psi. Straps with a low breaking elongation are unsuitable.

Distributed By:

Allstrap

1719 Kenny Rd

Columbus, OH, 43212

5 CHART OF TYPES A332

Item No.	Model	Strap width	Strap thickness
13.2250	A332/9.5/0.38-0.50	9.5mm / 3/8"	0.38 - 0.50 mm / 0.015 - 0.020"
13.2260	A332/10/0.38-0.50	10.0mm	0.38 - 0.50 mm / 0.015 - 0.020"
13.2270	A332/12.7/0.38-0.50	12.7mm / 1/2"	0.38 - 0.50 mm / 0.015 - 0.020"
13.2280	A332/13/0.38-0.50	13.0 mm	0.38 - 0.50 mm / 0.015 - 0.020"

6 OPERATION



When handling strap, always wear protective gloves and safety glasses with side shields which conform to ANSI Standard Z87.1.



Feeding the strapping around the package

The strapping is fed around the package in the direction as shown in the illustration. The strapping end is held tightly with the left hand and pulled firmly towards the operator with the right hand.

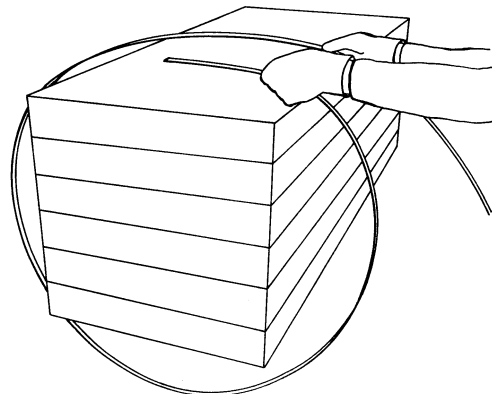

Loading the strapping

The rocker is raised with the right hand. The left hand inserts the two straps lying precisely upon another into the tool until they hit the strap stops. The lower strap end must slightly protrude the end of the base plate. Be certain that the strapping is held by the strap guide.

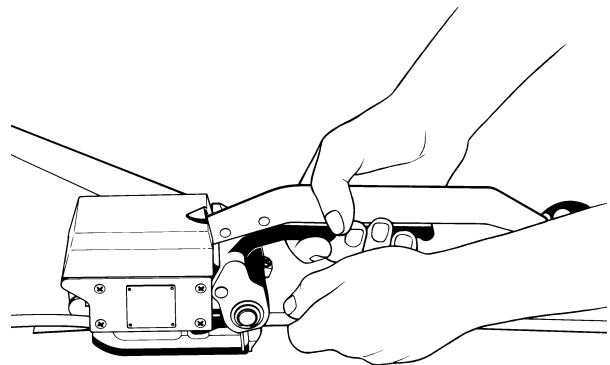

Distributed By:

Allstrap

1719 Kenny Rd
Columbus, OH, 43212

Tensioning the strapping

The tool is held tightly with the left hand being placed on the sealing lever. The tensioning handle is now moved forward and backward with the right hand until the desired tension is attained.

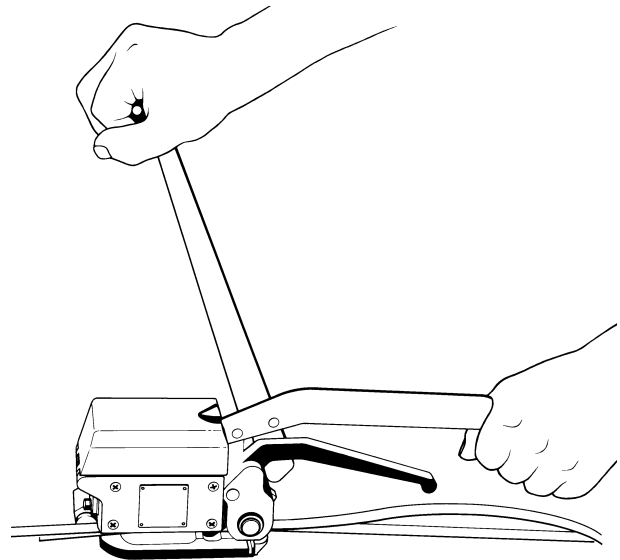

Sealing the strapping

The sealing lever is moved forward using the left hand until it hits the stop. The lever is then moved back to its initial position. When sealing, the right hand absorbs the sealing force by holding the tensioning handle.

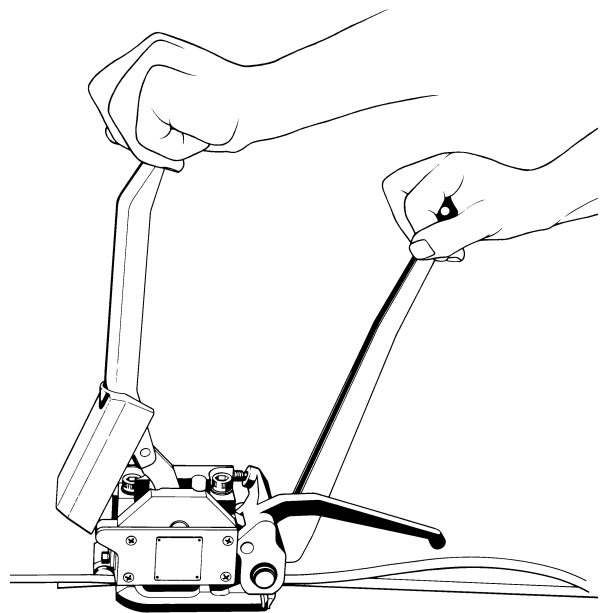

Releasing the tool

Hold the cut off strap end with the left hand, lift the rocker with the right hand and push the tool from the applied strap to the right.

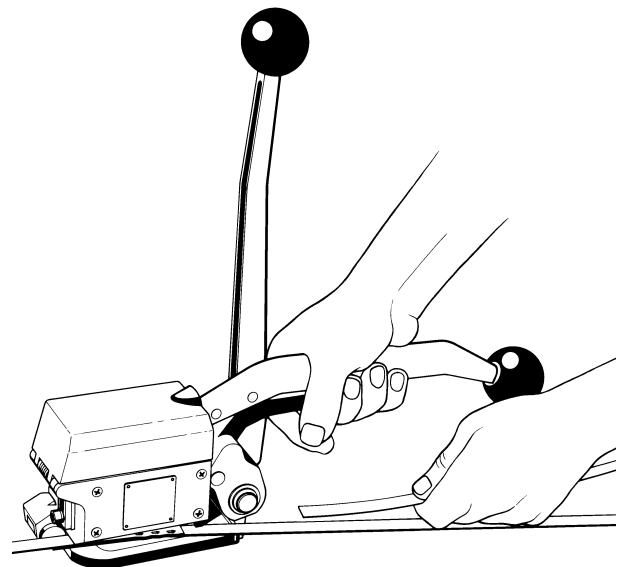

Distributed By:
Allstrap

1719 Kenny Rd
Columbus, OH, 43212

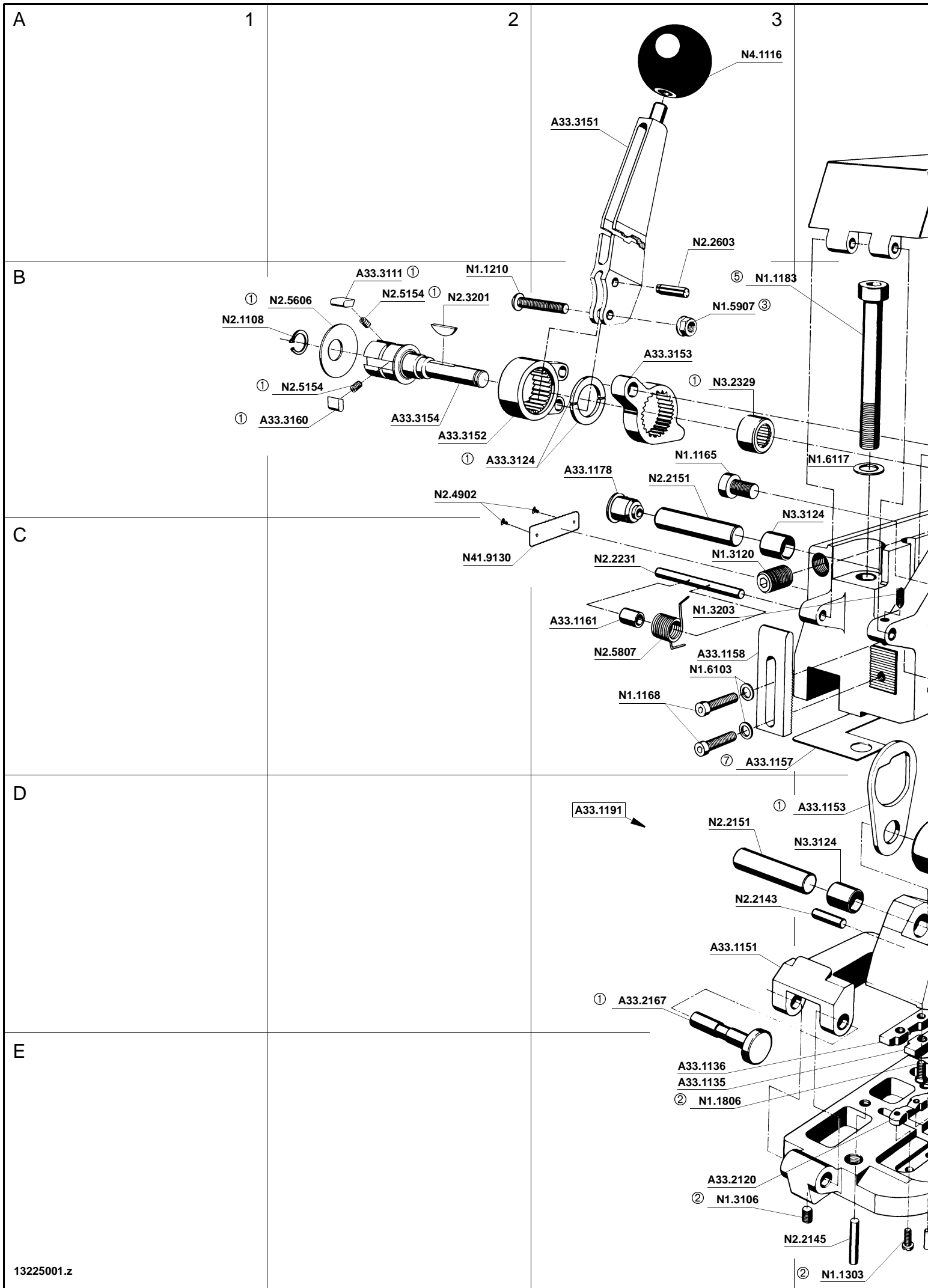

A

1

2

3



B

C

D

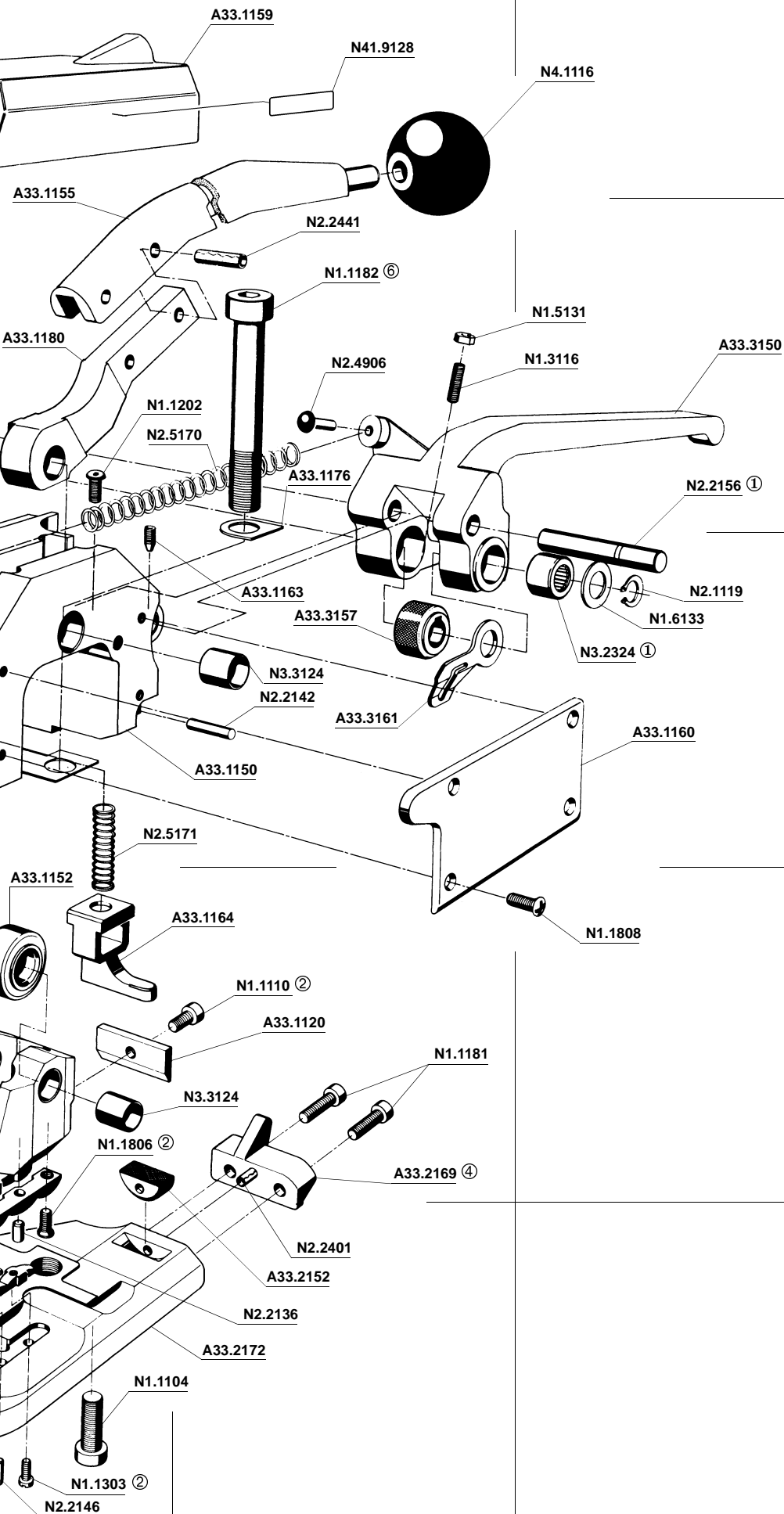
E



- ① ESSO Beacon 2
- ② Loctite 222
- ③ Loctite 243
- ④ Loctite 638
- ⑤  40 Nm
- ⑥  70 Nm
- ⑦ Compensation

7 SPARE PARTS LIST 13.2250.01

13.2250.01	A332/9.5/0.38-0.50		A332.0006.01			26.11.99
Item-No.		in group	Pcs.	Description	Dimension	Field
A33.1120	*		1	SHEAR BLADE		D5
A33.1135	*		1	DIE HALF		E3
A33.1136	*		1	DIE HALF		E3
[A33.1150]			1	HOUSING		C5
A33.1151		A33.1191	1	DIE AND CUTTER SUPPORT		D3
A33.1152		A33.1191	1	ROLLER		D4
A33.1153		A33.1191	1	LINK		D4
A33.1155			1	SEALING HANDLE		A4
[A33.1157]			1	SHIM		C3
A33.1158			1	STOP		C3
A33.1159			1	COVER		A5
A33.1160			1	COVER		C6
A33.1161			1	BUSH		C3
A33.1163			1	SOCKET SET SCREW		C5
A33.1164			1	EJECTOR		D5
A33.1176			1	WASHER		B5
A33.1178			1	TRUNNION		B3
A33.1180			1	SEALING CAM		B4
[A33.1191]			1	DIE AND CUTTER SUPPORT		D3
A33.2120	*		1	PUNCH		E3
A33.2152	*		1	GRIPPER		E5
A33.2167			1	LIMIT BOLT		D3
A33.2169			1	STRAP STOP		D5
A33.2172			1	BASE PLATE		E5
A33.3111			2	CATCH PAWL		B2
A33.3124			2	RING HALF		B2
A33.3150			1	ROCKER		B6
A33.3151			1	TENSION HANDLE		A3
A33.3152			1	DRIVER		B2
A33.3153			1	LOCKING RING		B3
[A33.3154]			1	TENSION SHAFT		B2
A33.3157	*		1	TENSIONING WHEEL		C5
A33.3160	*		2	CATCH PAWL		B2
A33.3161			1	STRAP GUIDE		C5
N1.1104			1	SCREW	M8 X 20	E4
N1.1110			1	SCREW	M5 X 8	D5
N1.1165		A33.1150	1	SCREW	M8 X 10	B3
N1.1168			2	SCREW	M5 X 16	C3
N1.1181			2	SCREW	M5 X 12	D5
N1.1182			1	SCREW	M10 X 1 X 80	B5
N1.1183			1	SCREW	M8 X 1 X 80	B3
N1.1202			1	SCREW	M5 X 10	B4
N1.1210			1	SCREW	M6 X 25	B2
N1.1303			2	SCREW	M2 X 8	E4
N1.1806			4	SCREW	M4 X 10	D4+
N1.1808			4	SCREW	M4 X 10	D6
N1.3106			1	SOCKET SET SCREW	M5 X 6	E3
N1.3116			1	SOCKET SET SCREW	M5 X 25	B6
N1.3120			1	SOCKET SET SCREW	M12 X 12	C3
N1.3203			1	SOCKET SET SCREW	M4 X 8	C3
N1.5131			1	HEXAGON NUT	M5	B6

[] = Group

* = Wearing parts

13.2250.01	A332/9.5/0.38-0.50		A332.0006.01			26.11.99
Item-No.		in group	Pcs.	Description	Dimension	Field
N1.5907			1	HEXACON NUT	M6	B3
N1.6103			2	WASHER	5.3 X 9.5 X 1	C3
N1.6117			1	WASHER	8,4 X 17 X 1,6	B4
N1.6133			1	WASHER	12,2 X 22 X 1	C6
N2.1108			1	SECURITY RING	E20	B1
N2.1119			1	SECURITY RING	E10	C6
N2.2136		A33.1191	2	PARALLEL PIN	4 H6 X 10	E5
N2.2142			1	PARALLEL PIN	4 M6 X 28	C5
N2.2143		A33.1191	1	PARALLEL PIN	5 H6 X 16	D3
N2.2145			2	PARALLEL PIN	4 H6 X 18	E4
N2.2146			1	PARALLEL PIN	2 M6 X 10	E4
N2.2151		A33.1191	1	PARALLEL PIN	12 H6 X 39	D3
N2.2151			1	PARALLEL PIN	12 H6 X 39	B3
N2.2156			1	PARALLEL PIN	10 H6 X 58	B6
N2.2231			1	PARALLEL PIN	5 H8 X 50	C3
N2.2401			1	DOWEL PIN	3 X 10	E5
N2.2441			2	DOWEL PIN	6 X 20 MM	B5
N2.2603			1	GROOVED PIN	6 X 16	A3
N2.3201			1	WOODRUFF KEY	4 X 6,5 X 15,72	B2
N2.4902			2	HAMMER HEAD BOLT	1,85 X 4,76	B2
N2.4906			1	HAMMER HEAD BOLT	5,31 X 12,7	B5
N2.5154			4	PRESSURE SPRING	0.45 X 3.9 X 7	B2
N2.5170			1	PRESSURE SPRING	2 X 9.8 X 96	B4
N2.5171			1	PRESSURE SPRING	1 X 8 X 26	C4
N2.5606			1	CUP SPRING	40X20.4X1	B2
N2.5807			1	TORSION SPRING		C3
N3.2324			1	NEEDLE BUSH		C6
N3.2329			1	NEEDLE BUSH		B3
N3.3124		A33.1191	2	SLIDE-BEARING		D4+
N3.3124			2	SLIDE-BEARING		B3+
N41.9128			1	ADHESIVE LABEL		A5
N41.9130			1	LABEL	A332	C2
N4.1116			2	GRIP BALL		A3+

Distributed By:
Allstrap
 1719 Kenny Rd
 Columbus, OH, 43212

[] = Group

* = Wearing parts

8 SEAL CONTROL

A regular control of the seal is necessary. The seal can be checked visually and the person controlling can easily judge the quality of the seal. When checking the seal the following illustrations must be compared.

Correct seal

A correct seal must be conform to the illustration. This means that the depth with which the upper strap hooks into the lower one must be 1 – 1.5 mm (0.039 – 0.059”) in min. and must not exceed 2 mm (0.079”). The upper strap must be sheared clean and the cutter must not leave scratch marks on the lower strap.

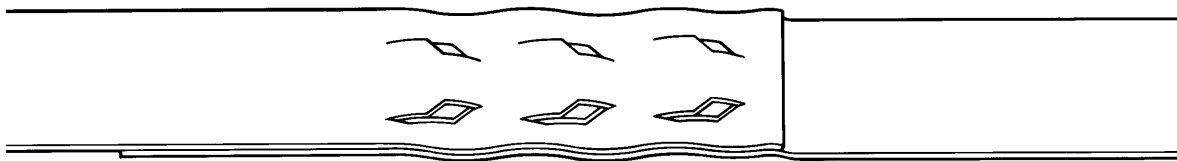

Incorrect seal (the sealing mechanism is adjusted too high)

This stamped seal is not deep enough and the upper strap is not sheared. The tensile strength of this seal is insufficient and the strapping must be taken away from the package. The tool must be readjusted immediately (see SEAL ADJUSTMENT).



Incorrect seal (the sealing mechanism is adjusted too low)

This stamped seal is too deep and the lower strap is scratched by the cutter. Although the tensile strength of this seal is sufficient the strapping must be taken away from the package because of the scratched lower strap. The tool must be readjusted immediately (see SEAL ADJUSTMENT).

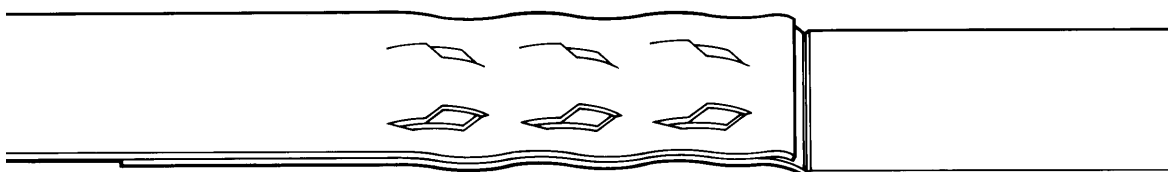

Distributed By:

Allstrap

1719 Kenny Rd

Columbus, OH, 43212

9 SEAL ADJUSTMENT

The sealing and cutting depth of the sealing mechanism and the cutter can be adjusted with the use of the hexagon key N4.1408 which is supplied with the tool as follows:

- Place tool as shown above.
- Loosen both screws N1.1168 and open them by approx. 3 revolutions.
- If sealing depth is not sufficient reset stop in the direction of the base plate.
- If sealing depth is excessive reset stop in the direction of the body cover.
- Retighten screws N1.1168.

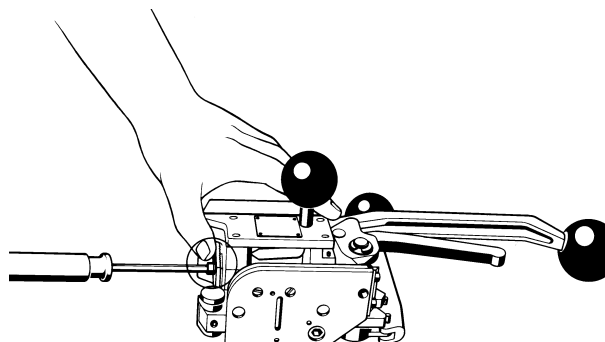

Assembly Instructions

After every disassembly it is essential to retighten screws N1.1182 and N1.1183 with the recommended torque when reassembling. The use of a torque key is necessary.

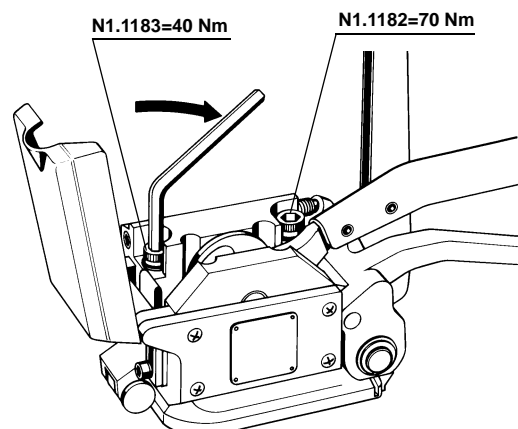

10 CLEANING

In case of heavy dirt and when painted straps are used the punch, dies, gripper and feed-wheel must be cleaned regularly.

Normally it is sufficient to blow out the parts with the help of an air gun.

Distributed By:

Allstrap

1719 Kenny Rd
Columbus, OH, 43212

11 ACCESSORIES

Using tool with horizontal handle

Upon request the tool can be supplied with a bolt A33.4101 and a grip ball N4.1116. When using tool for horizontal applications, the operator holds the tool on the grip ball during tensioning.

Install the handle as follows:

Remove side cover A33.1160 and break the marked position.

Reassemble side cover and screw bolt with mounted ball into the body.

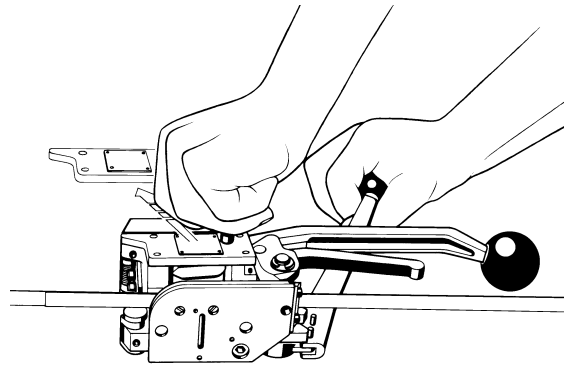

Suspension

It is possible to suspend the tool for strapping in vertical position.

Order the suitable suspension separately under item no. A33.0113.

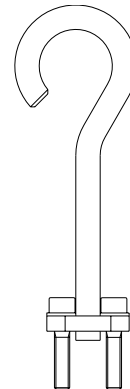

Distributed By:

Allstrap

1719 Kenny Rd
Columbus, OH, 43212