

# **FROMM**

OPERATION MANUAL / SPARE PARTS LIST

## **PNEUMATIC SEALLESS COMBINATION STRAPPING TOOL MODEL A391.0002**

13.5270.01

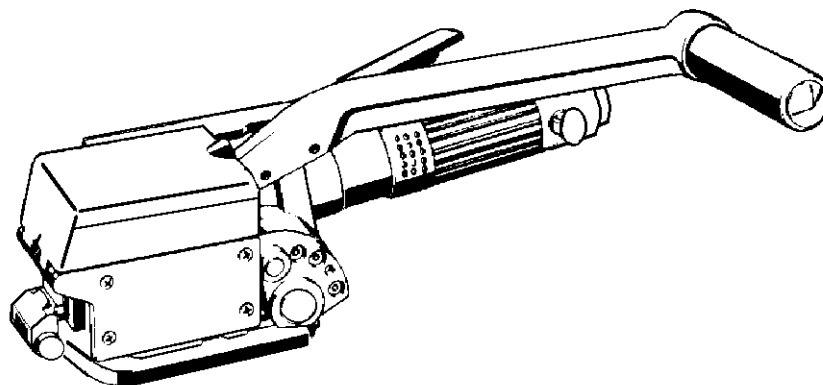

### **CE Declaration of conformity**

We declare that the machine A391  
is in conformity with the following standard or  
standardised documents:  
98/37/EEC

FROMM Holding AG  
Hinterbergstrasse 26  
CH - 6330 Cham  
03.04 2002

  
R.Fromm  
Director



Distributed By:  
**Allstrap**

1719 Kenny Rd  
Columbus, OH, 43212

	<b>INDEX</b>	<b>PAGE</b>
<b>1</b>	<b>SAFETY INSTRUCTIONS</b>	<b>3</b>
<b>2</b>	<b>WARRANTY CONDITIONS AND LIABILITY</b>	<b>4</b>
<b>3</b>	<b>APPROPRIATE USE</b>	<b>4</b>
<b>4</b>	<b>CHART OF TYPES A391.0002</b>	<b>4</b>
<b>5</b>	<b>TECNICAL DATA</b>	<b>5</b>
5.1	Sound information . . . . .	5
5.2	Vibration information . . . . .	5
<b>6</b>	<b>INSTALLATION</b>	<b>5</b>
6.1	Compressed air connection. . . . .	5
<b>7</b>	<b>COMPONENTS</b>	<b>6</b>
<b>8</b>	<b>USE</b>	<b>6</b>
<b>9</b>	<b>SPARE PARTS LIST 13.5270.01</b>	<b>10</b>
<b>10</b>	<b>SEAL CONTROL</b>	<b>13</b>
<b>11</b>	<b>SEAL ADJUSTMENT</b>	<b>14</b>
<b>12</b>	<b>MAINTENANCE</b>	<b>14</b>
12.1	Air - unit . . . . .	14
12.2	Cleaning . . . . .	14
12.3	Lubrication. . . . .	14
<b>13</b>	<b>ACCESSORIES</b>	<b>15</b>
13.1	Suspension A33.0113 . . . . .	15
13.2	Using tool with horizontal handle. . . . .	15

Distributed By:

**Allstrap**1719 Kenny Rd  
Columbus, OH, 43212

# 1 SAFETY INSTRUCTIONS

Read these instructions carefully. Failure to follow these instructions can result in severe personal injury.

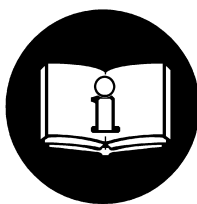

## Eye injury hazard

Failure to wear safety glasses with side shields can result in severe eye injury or blindness. Always wear safety glasses with side shields which conform to ANSI Standard Z87.1.



## Operation

Tool must not be used by persons not properly trained in their use. Before tensioning strap, read and understand the tool operating instructions. Failure to follow the operating instructions or improper load positioning could result in strap breakage.

Become familiar with your tool and keep fingers away from areas that can pinch or cut.

## Joints

You are fully responsible to review the joints made by your tool. Become familiar with the seal control and seal adjustment described in this operation manual. Misformed joints may not secure the load and could cause serious injury. Never handle or ship any load with improperly formed joints.

## Dispensing strap

Only dispense strap from a dispenser specifically designed for strap.

Tuck strap end back into dispenser when not in use.

## Protective gloves

When handling strap, always wear protective gloves.



## Strap warnings

Never use strap as a means of pulling or lifting loads. Failure to follow these warnings can result in severe personal injury.

## Strap breakage hazard

Improper operation of the tool, excessive tensioning, using strap not recommended for this tool or sharp corners on the load can result in a sudden loss of strap tension or in strap breakage during tensioning, which could result in the following:

- A sudden loss of balance causing you to fall.
- Both tool and strap flying violently towards your face.

Note as follows:

- If the load corners are sharp, use edge protectors.
- Place the strap correctly around a properly positioned load.
- Positioning yourself in-line with the strap, during tensioning and sealing, can result in severe personal injury from flying strap or tool. When tensioning or sealing, position yourself to one side of the strap and keep all bystanders away.
- Use the correct strap quality, strap width, strap gauge and strap tensile strength recommended in this manual for your tool. Using strap not recommended for this tool can result in strap breakage during tensioning.

## Cutting tensioned strap

When cutting strapping, use the proper strapping cutter and keep other personnel and yourself at a safe distance from the strap. Always stand to side of the strap, away from the direction the loosened strap end will fly. Use only cutters designed for strap and never hammers, pliers, hacksaws, axes, etc.

## Fall hazard

Keep your working area tidy. Untidiness of your working area may cause a risk of injury. Maintaining improper footing and/or balance when operating the tool can cause you to fall. Before tensioning and especially in elevated areas, always establish good balance. Both feet should be securely placed on a flat, solid surface, especially when working in elevated areas. Do not use the tool when you are in an awkward position.

Pay attention to the rules and regulations for preventions of accident which are valid for the work place.

## Tool hazards

A well maintained tool is a safe tool!

Check tool regularly for broken or worn parts. Do not operate a tool with broken or worn parts.

Never modify any tool. Modification can result in severe bodily injury.

Distributed By:

**Allstrap**

1719 Kenny Rd

Columbus, OH, 43212

## 2 WARRANTY CONDITIONS AND LIABILITY

FROMM Holding AG warrants all its strapping tools and machine heads during a period of 24 months from the date of installation at the end-user's sight by the distributor, however, not later than 30 months from the date of shipment to the distributor of FROMM Holding AG.

The warranty includes all deficiencies clearly resulting from poor manufacturing or faulty materials. Damage claims as a result of production shutdowns and claims for damage to persons and to property resulting from warranty deficiencies cannot be asserted by the customer.

The warranty excludes:

- wearing parts,
- deficiencies resulting from improper installing, incorrect handling and maintaining the tool,
- deficiencies resulting from using the tool without or with defective security- and safety devices,
- disregard of directions in the operation manual,
- arbitrary modifications of the tool,
- deficient control of wearing parts,
- deficient repair works of the tool.
- Use of consumable products not recommended by FROMM Holding AG

We reserve the right to modify the product at any time in order to improve its quality.

## 3 APPROPRIATE USE

The tool model A391 has been designed to strap packages with steel strapping exclusively.

The warranty / liability excludes:

- non appropriate use of the tool,
- disregard of directions in the operation manual,
- disregard of control- and maintenance instructions.

## 4 CHART OF TYPES A391.0002

Item-No.	Model	Strap width Ultraflex		Strap thickness Ultraflex		Max. tensioning speed	
		mm	inch	mm	inch	mm/s	inch/s
13.5270	A391/12.7/0.38-0.58	12.7	1/2	0.38-0.58	.015 -.023	100	4
13.5280	A391/13/0.38-0.58	13	-	0.38-0.58	.015 -.023	100	4
13.5290	A391/16/0.38-0.58	16	5/8	0.38-0.58	.015 -.023	100	4
13.5310	A391/19/0.38-0.58	19	3/4	0.38-0.58	.015 -.023	100	4

Ultraflex = Strap with max. tensile strength of 1100 N/mm<sup>2</sup> (160 000 psi)

Distributed By:

**Allstrap**

1719 Kenny Rd  
Columbus, OH, 43212

## 5 TECHNICAL DATA

### Dimensions

	Tool:	Package:
Length:	385 mm / 15.16"	460 mm / 18.11"
Width:	175 mm / 6.89"	240 mm / 9.45"
Height:	140 mm / 5.51"	185 mm / 7.28"
Weight:	5.1 kg/11.2 lbs	0.9 kg/2.0 lbs

### Compressed air

Joining thread:	G 1/4"
Tube:	Min. inside diameter = 8 mm / 5/16"
Maximum air pressure:	6 bar / 87psi
Air consumption:	450 NI / 15.8 cu.ft. per minute motor tensioning

### Tensioning force

6 bar / 87psi: approx. 6000N / 1350 lbs

### Joint strength

Approx. 80% of the strap's tensile strength.

### Steel strap

Width:	12.7 - 19 mm / 1/2" - 3/4" (see chart of types)
Thickness:	0.38 - 0.58 mm / .015 - .023"
Quality:	The A391 model allows the use of all current steel straps with tensile strengths ranging from 850 - 1100 N/mm <sup>2</sup> (123 000 -160 000 psi) . Straps with low breaking elongation are not suitable.

### 5.1 Sound information

The A-weighted equivalent continuous sound level at the work place of the machine operator is typical 79 dB (A).

This value was determined according to DIN 45 635 T3 (11.85).

### 5.2 Vibration information

The weighted effective value of the acceleration typically amounts to less than 2,5m/s<sup>2</sup>.

This value was determined according to DIN EN 28 662 T1 (01.93).

## 6 INSTALLATION

### 6.1 Compressed air connection

The air tube is preferably connected to the tool using a quick coupling. An air unit consisting of a separator for water and dirt, a pressure regulator with a manometer and a lubricator should be installed within a distance of 15 ft / 5 meters. The compressed air must be free from dirt, rust and moisture.

Distributed By:

**Allstrap**

## 7 COMPONENTS

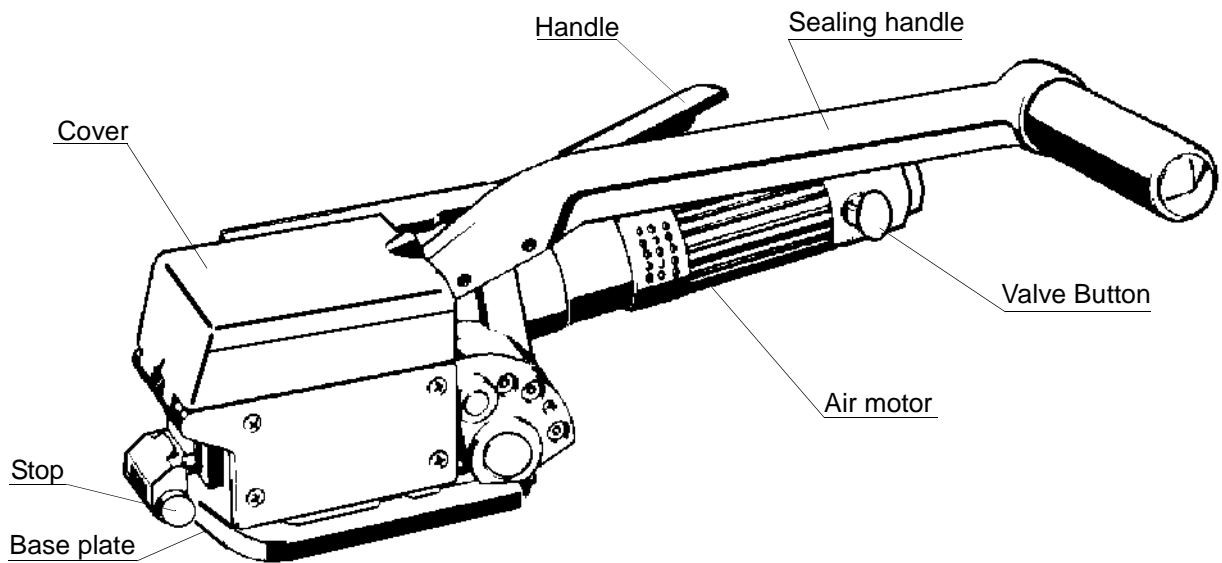

## 8 USE

### Feeding the strap around the package

The strap is fed around the package in the direction as shown in the illustration. The end of the strap is held tightly with the left hand and pulled firmly towards the operator with the right hand.

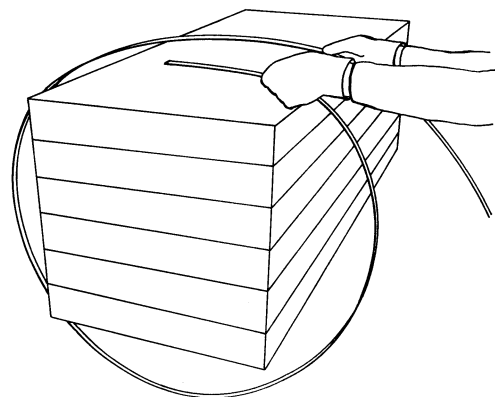

Always wear safety glasses with side shields which conform to ANSI Standard Z87.1.



When handling strap, always wear protective gloves.

### Loading the strap

Lift and hold the air motor with the right hand. The left hand inserts the two straps lying precisely upon another into the tool until they hit the strap stops. The lower strap end must slightly protrude the end of the base plate. The feed wheel is lowered to the strap by releasing the air motor.

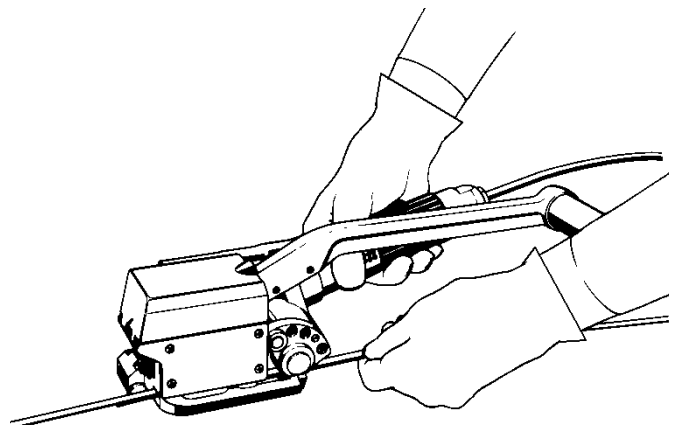

Distributed By:  
**Allstrap**

1719 Kenny Rd  
Columbus, OH, 43212

## Tensioning the strap

Tensioning the strap by pressing the valve button. It is possible to change tensioning force by adjusting the pressure regulator at the air unit.

### Attention!

Never exceed the maximum air pressure of 6 bar / 87 psi.

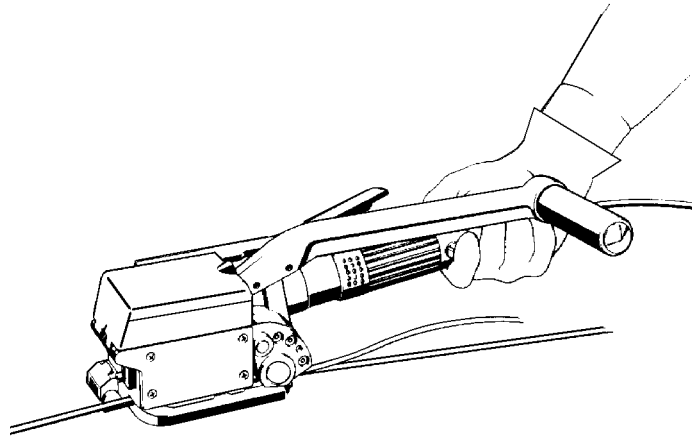

## Sealing the strap

The sealing handle is moved forward using the left hand until it hits the stop. Then the handle is moved back in its initial position. While sealing the right hand absorbs the sealing force by holding the air motor.

### Attention!

Don't seal with air motor running.

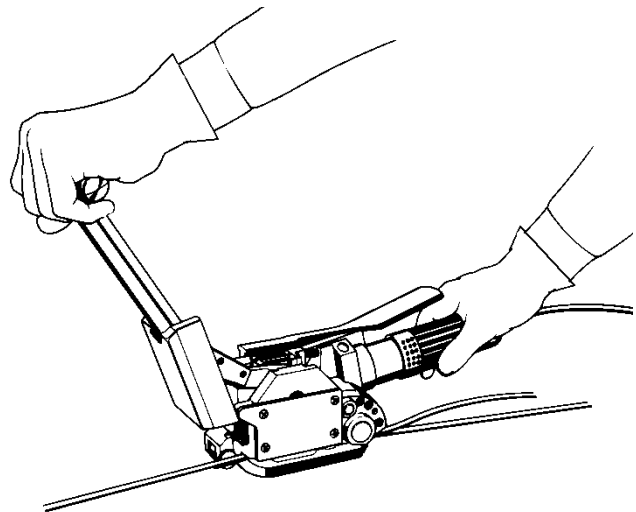

## Releasing the tool

Lift the air motor with the right hand and remove the tool from the sealed strap to the right.

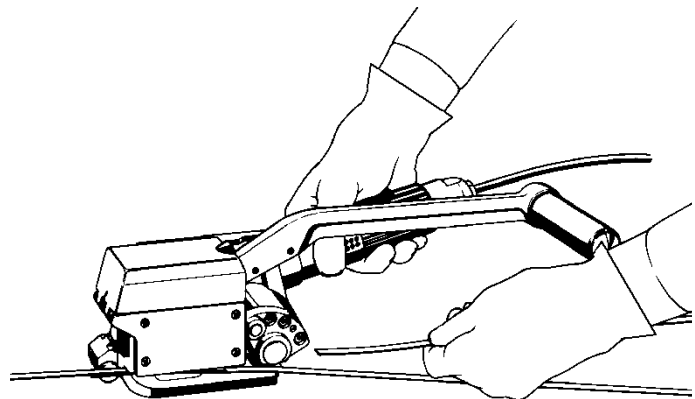

Distributed By:

**Allstrap**

1719 Kenny Rd  
Columbus, OH, 43212

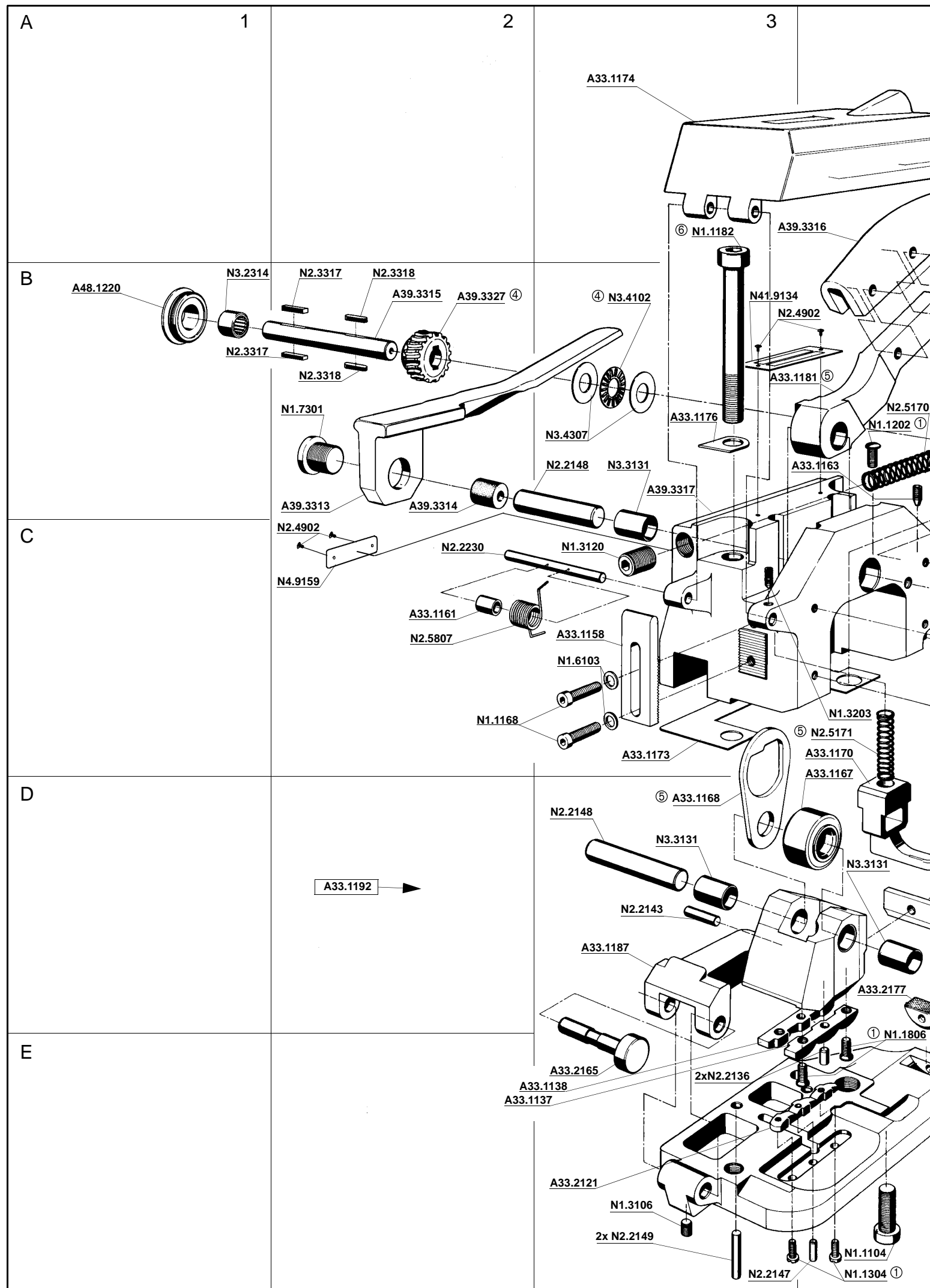



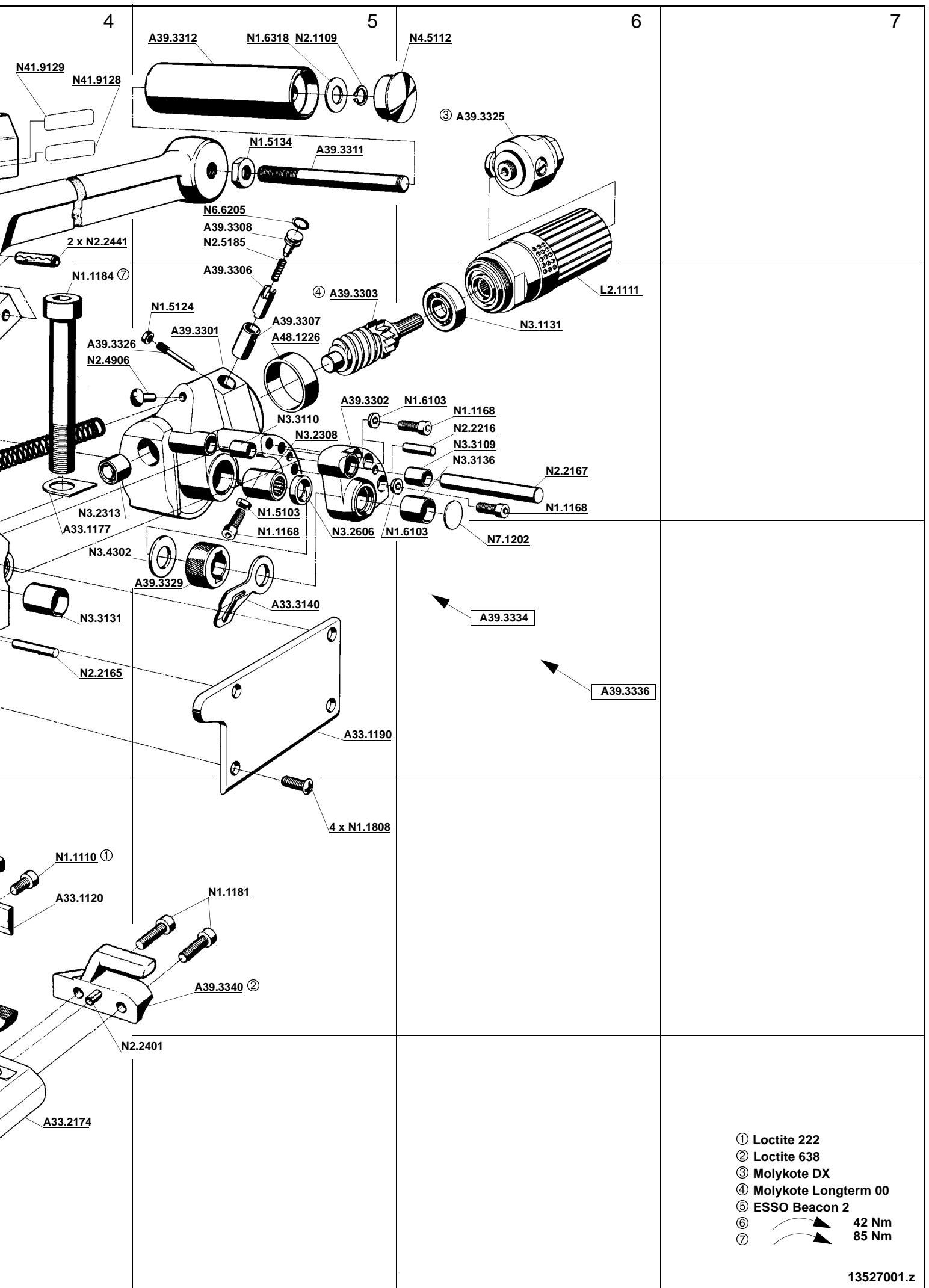

- ① Loctite 222
- ② Loctite 638
- ③ Molykote DX
- ④ Molykote Longterm 00
- ⑤ ESSO Beacon 2
- ⑥ 42 Nm
- ⑦ 85 Nm

## 9 SPARE PARTS LIST 13.5270.01

13.5270.01	A391/12.7/0.38-0.58		A391.0001.01		26/06/98
Item-No.		Pcs.	Description	Dimension	Field
A33.1120	*	1	SHEAR BLADE		D4
A33.1137	*	1	DIE HALF		E3
A33.1138	*	1	DIE HALF		E3
A33.1158		1	STOP		C3
A33.1161		1	BUSH		C2
A33.1163		1	SOCKET SET SCREW		B4
A33.1167	->[A33.1192]	1	ROLLER		C4
A33.1168	->[A33.1192]	1	LINK		D3
A33.1170		1	EJECTOR		C4
[A33.1173]		1	SHIM		C3
A33.1174		1	COVER		A3
A33.1176		1	WASHER		B3
A33.1177		1	WASHER		C4
A33.1181		1	SEALING CAM		B4
[A33.1187]	->[A33.1192]	1	DIE AND CUTTER SUPPORT		D3
A33.1190		1	COVER		C5
[A33.1192]		1	DIE AND CUTTER SUPPORT		D2
A33.2121	*	1	PUNCH		E3
A33.2165		1	LIMIT BOLT		E3
A33.2174		1	BASE PLATE		E4
A33.2177	*	1	GRIPPER	HSS	D4
A33.3140		1	STRAP GUIDE		C5
[A39.3301]	->[A39.3334]	1	GEAR BODY		B5
A39.3302	->[A39.3334]	1	END COVER		B5
A39.3303	->[A39.3336]	1	WORM		B5
A39.3306	->[A39.3336]	1	LOCKING BOLT		B5
A39.3307	->[A39.3336]	1	BUSHING		B5
A39.3308	->[A39.3336]	1	SPRING GUIDE		A5
A39.3309	->[A39.3325]	1	VALVE BODY		--
A39.3311		1	HANDLE SHAFT		A5
A39.3312		1	TANG		A5
A39.3313		1	TANG		B2
A39.3314		1	TRUNNION		B2
A39.3315	->[A39.3336]	1	TENSION SHAFT		B2
A39.3316		1	SEALING HANDLE		A4
[A39.3317]		1	HOUSING		B3
[A39.3318]	->[A39.3325]	1	WASHER SET		--
[A39.3325]		1	VALVE HEAD		A6
A39.3326	->[A39.3336]	1	SOCKET SET SCREW		B4
A39.3327	->[A39.3336]	1	WORM WHEEL		B2
A39.3329	* ->[A39.3336]	1	TENSIONING WHEEL		C5
[A39.3334]	->[A39.3336]	1	GEAR BODY		B5
[A39.3336]		1	GEAR		C6
A39.3340		1	STRAP STOP	1/2"	D5
A48.1220	->[A39.3334]	1	END COVER		B1
A48.1226	->[A39.3336]	1	BEARING JACKET		B5
[L2.1111]		1	AIR MOTOR		B6
L2.1201	->[L2.1111]	1	EXHAUST RING		--
L2.1203	->[L2.1212]	1	PLASTIC JACKET		--
L2.1206	->[A39.3325]	1	ADAPTOR		--
L2.1208	->[A39.3325]	1	SEALING SCREW		--

[ ] = Group

\* = Wearing parts

13.5270.01	A391/12.7/0.38-0.58		A391.0001.01		26/06/98
Item-No.		Pcs.	Description	Dimension	Field
[L2.1212]	->[L2.1111]	1	HOUSING		--
L2.1213	->[A39.3325]	1	BUTTON		--
L2.1214	->[A39.3325]	1	VALVE PISTON		--
L2.1301	->[L2.1111]	1	END PLATE		--
L2.1302	->[L2.1111]	1	PARALLEL PIN		--
L2.1303	->[L2.1111]	1	CYLINDER		--
L2.1304	* ->[L2.1111]	5	VANE		--
L2.1308	->[L2.1111]	1	SILENCER		--
L2.1310	->[L2.1111]	2	NEEDLE CAGE		--
L2.1312	->[L2.1111]	2	SHAFT		--
L2.1313	->[L2.1111]	1	BEARING RING		--
L2.1314	->[L2.1111]	1	END PLATE		--
L2.1402	->[L2.1111]	48	BEARING NEEDLE		--
L2.1403	->[L2.1111]	3	GEAR WHEEL		--
L2.1404	->[L2.1111]	3	SHAFT		--
L2.1405	->[L2.1111]	1	BEARING RING		--
L2.1415	->[L2.1111]	1	PLANET SHAFT		--
L2.1501	->[L2.1111]	2	GEAR WHEEL		--
L2.1502	->[L2.1111]	1	ROTOR		--
L2.1503	->[L2.1111]	1	HEXACON NUT		--
L2.1504	->[L2.1111]	1	PLANET SHAFT		--
L2.1505	->[L2.1111]	1	KEY		--
N1.1104		1	SCREW	M8 X 20	E4
N1.1110		1	SCREW	M5 X 8	D4
N1.1168		2	SCREW	M5 X 16	C2
N1.1168	->[A39.3334]	3	SCREW	M5 X 16	B6
N1.1168	->[A39.3336]	1	SCREW	M5 X 16	C5
N1.1181		2	SCREW	M5 X 12	D5
N1.1182		1	SCREW	M10 X 1 X 80	A3
N1.1184		1	SCREW	M12 X 1,25 X 80	B4
N1.1202		1	SCREW	M5 X 10	B4
N1.1304		2	SCREW	M3 X 8	E4
N1.1806		4	SCREW	M4 X 10	E4
N1.1808		4	SCREW	M4 X 10	D5
N1.3106		1	SOCKET SET SCREW	M5 X 6	E3
N1.3120		1	SOCKET SET SCREW	M12 X 12	C3
N1.3203		1	SOCKET SET SCREW	M4 X 8	C4
N1.5103	->[A39.3336]	1	HEXAGON NUT	M5	B5
N1.5124	->[A39.3336]	1	HEXAGON NUT	M4	B5
N1.5134		1	HEXAGON NUT	M12	A5
N1.6103		2	WASHER	5.3 X 9.5 X 1	C3
N1.6103	->[A39.3334]	3	WASHER	5.3 X 9.5 X 1	B6+
N1.6318		1	SPACER WASHER	12 X 18 X 1,2	A5
N1.6701	->[L2.1111]	2	TOOTH LOCK WASHER		--
N1.7301		1	SEALING SCREW	M18 X 1,5 X 12	B2
N2.1109		1	SECURITY RING	E12	A5
N2.2136	->[A33.1192]	2	PARALLEL PIN	4 H6 X 10	E3
N2.2143	->[A33.1192]	1	PARALLEL PIN	5 H6 X 16	D3
N2.2147		1	PARALLEL PIN	3 M6 X 10	E3
N2.2148		1	PARALLEL PIN	14 H6 X 48	B3
N2.2148	->[A33.1192]	1	PARALLEL PIN	14 H6 X 48	D3
N2.2149		2	PARALLEL PIN	4 H6 X 22	E3
N2.2165		1	PARALLEL PIN	4M6 X 34	C4

[ ] = Group

\* = Wearing parts

13.5270.01	A391/12.7/0.38-0.58		A391.0001.01		26/06/98
Item-No.		Pcs.	Description	Dimension	Field
N2.2167		1	PARALLEL PIN	10 H8 X 58	B6
N2.2216	->[A39.3334]	1	PARALLEL PIN	5 H8 X 16	B6
N2.2230		1	PARALLEL PIN	5 H8 X 60	C2
N2.2401		1	DOWEL PIN	3 X 10	E5
N2.2414	->[A39.3325]	1	DOWEL PIN	2 X 12 MM	--
N2.2441		2	DOWEL PIN	6 X 20 MM	A4
N2.3317	->[A39.3336]	2	KEY	4 X 4 X 16	B1+
N2.3318	->[A39.3336]	2	KEY	4 X 4 X 22	B2
N2.4902		4	HAMMER HEAD BOLT	1,85 X 4,76	B4+
N2.4906	->[A39.3334]	1	HAMMER HEAD BOLT	5,31 X 12,7	B4
N2.5102	->[A39.3325]	1	PRESSURE SPRING	0.6 X 8 X 14/6	--
N2.5170		1	PRESSURE SPRING	2 X 9.8 X 96	B4
N2.5171		1	PRESSURE SPRING	1 X 8 X 26	C4
N2.5185	->[A39.3336]	1	PRESSURE SPRING	0.63X5.5X12	A5
N2.5807		1	TORSION SPRING		C2
N3.1102	->[L2.1111]	4	BALL BEARING		--
N3.1108	->[L2.1111]	1	BALL BEARING		--
N3.1109	->[L2.1111]	1	BALL BEARING		--
N3.1131	->[A39.3336]	1	BALL BEARING		B6
N3.2308	->[A39.3334]	1	NEEDLE BUSH		B5
N3.2313	->[A39.3334]	1	NEEDLE CASE		B4
N3.2314	->[A39.3334]	1	NEEDLE CASE		B1
N3.2606	->[A39.3334]	1	PACKING RING		C5
N3.3109	->[A39.3334]	1	SLIDE-BEARING		B6
N3.3110	->[A39.3334]	1	SLIDE-BEARING		B5
N3.3131		2	SLIDE-BEARING		B3+
N3.3131	->[A33.1192]	2	SLIDE-BEARING		D3+
N3.3136	->[A39.3334]	1	SLIDE-BEARING		B6
N3.4102	->[A39.3336]	1	THRUST BEARING CAGE		B3
N3.4302	->[A39.3336]	1	SLIDING DISK		C4
N3.4307	->[A39.3336]	2	THRUST RACE		B3
N4.5112		1	PROTECTION PLUG		A6
N4.5113	->[A39.3325]	1	PROTECTION PLUG		--
N4.9159		1	LABEL	<<CE>>	C2
N41.9128		1	ADHESIVE LABEL		A4
N41.9129		1	ADHESIVE LABEL		A4
N41.9134		1	LABEL	A391	B4
N6.6201	->[A39.3325]	1	O-RING	4,3 X 1,4	--
N6.6205	->[A39.3325]	1	O-RING	9,2 X 1.78	--
N6.6205	->[A39.3336]	1	O-RING	9,2 X 1.78	A5
N6.6206	->[A39.3325]	1	O-RING	4,3 X 2,4	--
N7.1202	->[A39.3334]	1	SEALING DISK		C6

[ ] = Group

\* = Wearing parts

Distributed By:  
**Allstrap**  
 1719 Kenny Rd  
 Columbus, OH, 43212

## 10 SEAL CONTROL

A regular control of the seal is necessary. The seal can be checked visually and the person controlling can easily judge the quality of the seal. When checking the seal the following illustrations must be compared.

### Correct seal

A correct seal must conform to the illustration. This means that the depth with which the upper strap hooks into the lower one must be 1 - 1.5 mm in min. and 2 mm in max.. The upper strap must be sheared clean and the cutter must not leave scratch marks on the lower strap.

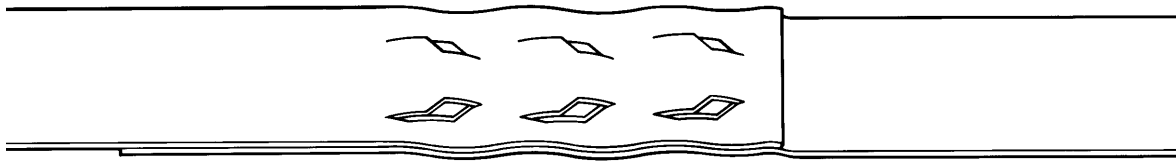

### Incorrect seal (the sealing mechanism is adjusted too high)

This stamped seal is not deep enough and the upper strap is not sheared. The tensile strength of this seal is insufficient and the strapping must be taken away from the package. The tool must be readjusted immediately (see SEAL ADJUSTMENT).



### Incorrect seal (the sealing mechanism is adjusted too low)

This stamped seal is too deep and the lower strap is scratched by the cutter. Although the tensile strength of this seal is sufficient the strapping must be taken away from the package because of the scratched lower strap. The tool must be readjusted immediately (see SEAL ADJUSTMENT).



Distributed By:

**Allstrap**

1719 Kenny Rd  
Columbus, OH, 43212

## 11 SEAL ADJUSTMENT

The sealing mechanisms stamping and cutting depth can be adjusted with the socket wrench N4.1408 delivered with the tool.

Procedure:

- Place the tool as shown.
- Loosen both screws N1.1168 and unscrew them about three rotations.
- If sealing mechanism is adjusted too high displace the stop in the direction of the base plate.
- If sealing mechanism is adjusted too low displace the stop in the direction of the cover.
- Tighten screws.

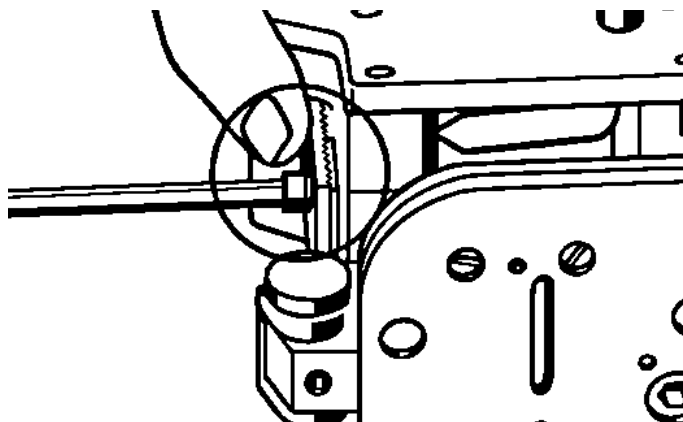

## 12 MAINTENANCE

Depending on the working conditions and the use of the tool the following maintenance has to be made periodically:

### 12.1 Air - unit

- Checking the air-pressure daily.
- Checking oil-level daily.
- The water separator must be emptied before it is full (unless automatic).
- The filter has to be cleaned following the instructions of the manufacturer of the air- unit.

### Oil for the air-unit

HL or CL ISO-VG 10

### 12.2 Cleaning

If impact of dirt and dust is considerable and if painted (cincoated) straps are used the feed wheel must be cleaned regularly. Normally it is sufficient to blow out this part by using an air gun.

### 12.3 Lubrication

The worm gear is filled with MOLYKOTE LONGTERM 00. Use the same type of grease after repairs. When being exchanged, all valve parts and other movable parts have to be greased with grease of type ESSO BEACON 2 or with any equivalent product.

### Assembling notice:

The screws N1.1182 and N1.1184 have to be tightened after each disassembling with the prescribed torques.  
The use of a torque wrench is absolutely necessary.

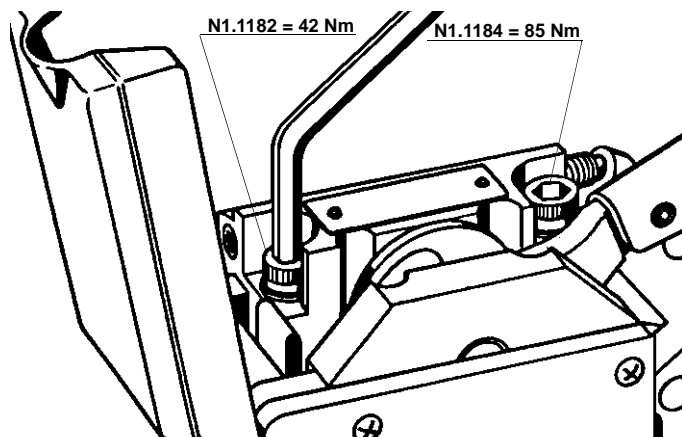

Distributed By:

**Allstrap**

1719 Kenny Rd  
Columbus, OH, 43212

## 13 ACCESSORIES

### 13.1 Suspension A33.0113

It is possible to suspend the tool for strapping in vertical position.

Order the suitable suspension separately under item no. A33.0113.

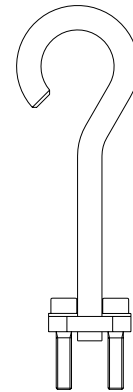

### 13.2 Using tool with horizontal handle

Upon request the tool can be supplied with a bolt A33.4101 and a grip ball N4.1116. When using tool for horizontal applications, the operator holds the tool on the grip ball during tensioning.

Install the handle as follows:

Remove side cover A33.1190 and break the marked position. Reassemble side cover and screw bolt with mounted ball into the body.

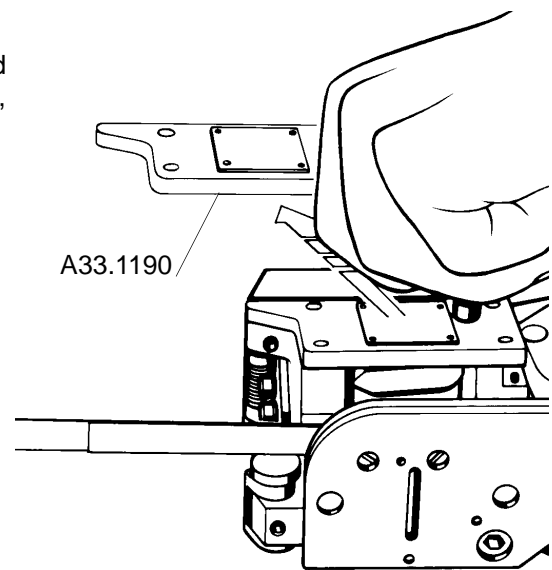

Distributed By:

**Allstrap**

1719 Kenny Rd  
Columbus, OH, 43212

Distributed By:

**Allstrap**

1719 Kenny Rd  
Columbus, OH, 43212